

Kawasaki Robotics ASTORINO

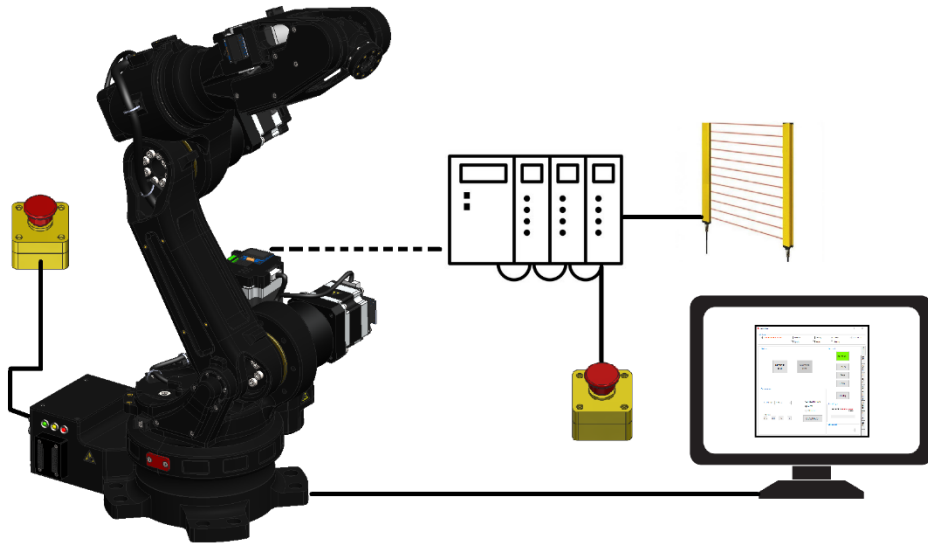

Documents for an incomplete machine

According to Machinery Directive 2006/42/EC

CONTENT

1. TECHNICAL SPECIFICATION	3
2. CONTENTS OF THE SET	6
3. INTENDED OPERATION	6
4. DECLARATION OF INCORPORATION	7
5. SAFETY INSTRUCTIONS	8
6. INSTALLATION INSTRUCTIONS	12
7. RISK ASSESSMENT	13
7.1. SAFETY FEATURES	13
7.2. RESIDUAL RISKS	14
7.2.2. PINCH OR HAND INJURY PLACES	17
7.2.3. RESIDUAL RISKS IN CASE OF POWER LOSS	18
8. INSTALLATION	19
8.1. INSTALLATION ENVIRONMENT	19
8.2. SAFETY MEASURES CONCERNING ROBOT INSTALLATION	19

1. Technical specification

Parameters		ASTORINO
Type		6-axis robot
Max. lifting capacity		2 kg
Number of axes		6
Max. range		578 mm
Repeatability		±0.5 mm
Motion range	JT1	±158°
	JT2	-90°÷127°
	JT3	0°÷168°
	JT4	±240°
	JT5	±120°
	JT6	±360°
Max. speed	JT1	60°/s
	JT2	40°/s
	JT3	56°/s
	JT4	120°/s
	JT5	127.5°/s
	JT6	156°/s
Allowable Moment	JT4	6.2 Nm
	JT5	1.45 Nm
	JT6	1.1 Nm
Work environment	Temperature	5–50°C
	Humidity	35–80%
Controller		Teensy 4.1
Inputs/outputs		8/8 (PNP 8 mA, NPN 15 mA)
Max. power draw		144 W
Power supply		100–240 V, 50–60 Hz
Weight		15 kg
Acoustic noise		<70dB
Mounting position		Floor
Material		ColorFabb xt-cf20 and ABS
Colour		Black
Options	8 channel 24V I/O module	24 V 8 × inputs/outputs
	7th axis	Linear track
	Vision system	OpenMV
	Belt tracking	Max. 2 encoders
	Dedicated inputs	4× 3.3V (24V option), real-time
Country of origin		Poland
Service		Astor Sp. z o.o. 31-112 Kraków, Poland info@astorino.com.pl

The motion ranges shown in the figures below are based on point P. For specifications of robot arms not shown in this manual, see the specification sheets, delivered separately.

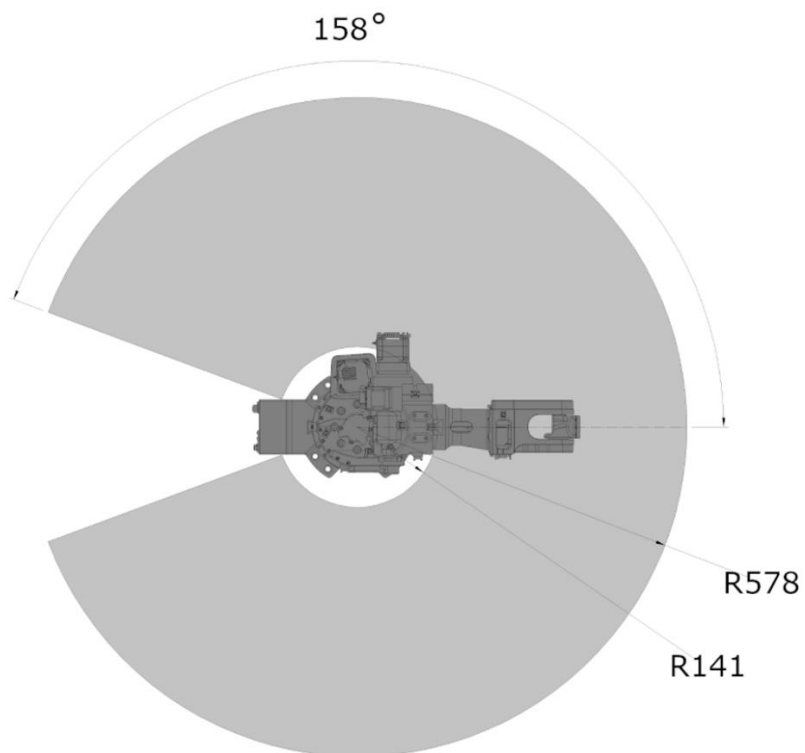
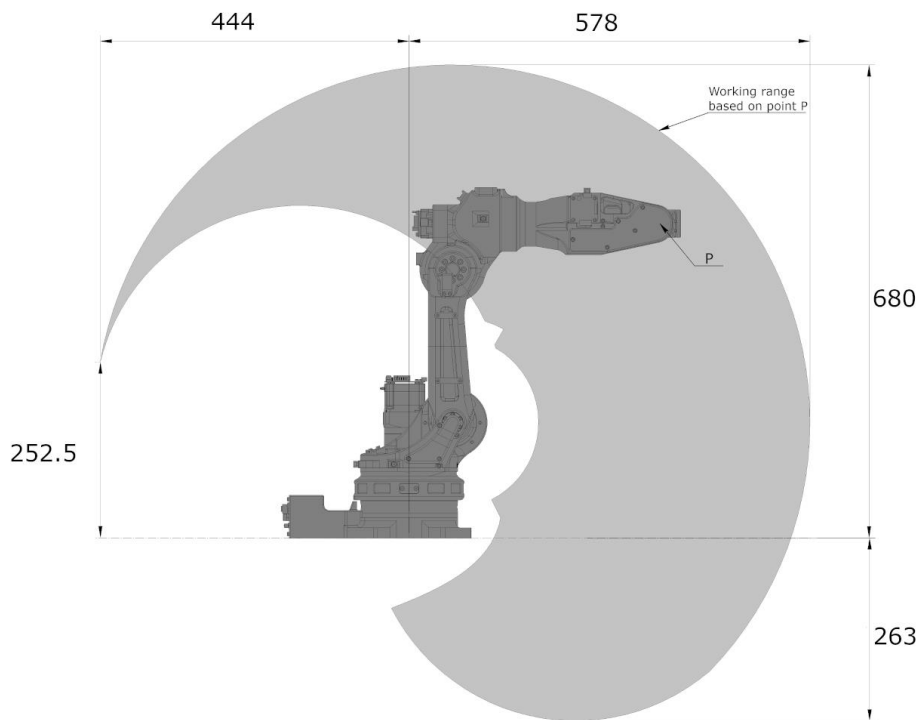

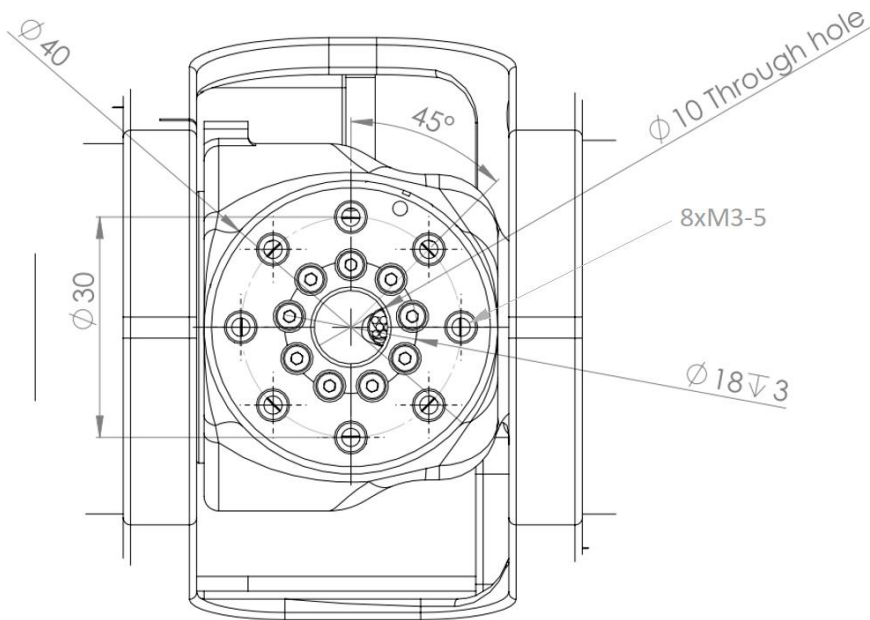
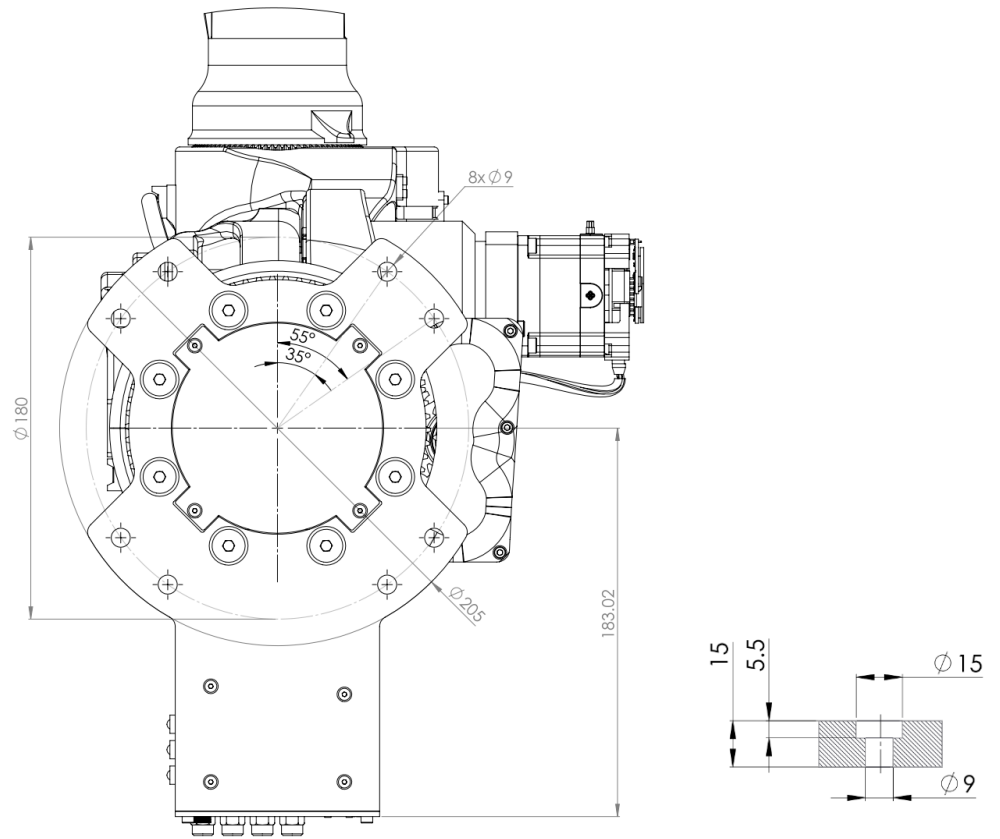

2. Contents of the set

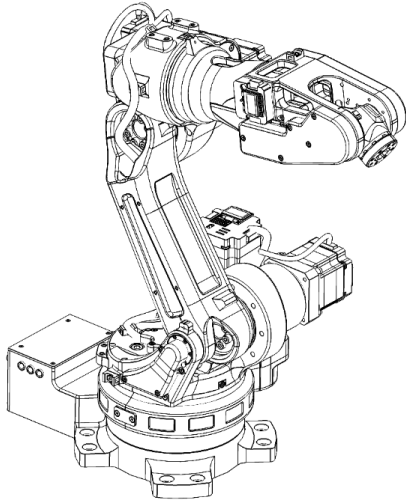

ASTORINO

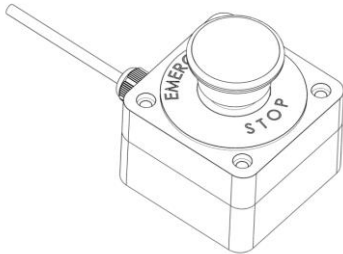

Emergency stop button

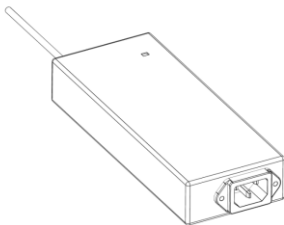

24 V DC power supply

3. Intended operation

The astorino robots are designed to move and position small loads or objects. astorino robots are meant to be educational robots, working in controlled environment of laboratories as training machines.

According to the Machine Directive 2006/42/EC astorino robot is a machinery specially designed and constructed for research purposes for temporary use in laboratories.

Furthermore, if are intended to be incorporated into or assembled with other machinery or other incomplete machinery or equipment in order to form a machine along with them in accordance with Machinery Directive 2006/42/EC

4. Declaration of incorporation

DECLARATION OF INCORPORATION OF PARTLY COMPLETED MACHINERY

No. 22/04/2022

Astor Sp. z o.o.

Ul. Smoleńsk 29, 31-112 Kraków

Declares with full responsibility that the product:

Educational robot astorino

is intended used as specially designed and constructed machine for research purposes in laboratories. Or to be incorporated into machinery or to be assembled with other machinery to constitute machinery covered by:

**Machine Directive
2006/42/EC**

**Low Voltage
Directive
2006/95/EC** relating
to electrical equipment
supplied voltage below
1000V

**EMC Directive
2004/108/CE**
relating to
electromagnetic
compatibility

the following standards have been applied:

**PN-EN ISO
12100:2012**

Machine safety - General design principles - Risk assessment and risk reduction
Electromagnetic compatibility (EMC) - Part 6-2: Generic standards - Resistance in industrial environments

**PN-EN 61000-6-
2:2008**

**PN-EN ISO 10218-
1:2011**

Robots and equipment for robotics - Safety requirements - Part 1: Industrial robots (ISO 10218-1: 2011)
Robots for work in an industrial environment - Safety requirements - Part 2: Robotic system and integration (ISO 10218-2: 2011)

**PN-EN ISO 10218-
2:2011**

Authorized representative and Person authorized to compile the Technical Documentation:

ASTOR Sp. z o.o
Smoleńsk 29, 31-112
Kraków
Marek Niewiadomski
Chief designer

.....
(Place and Date)

.....
Andrzej Garbacki, Member of the Board

5. Safety instructions



5.1. General information on safety

	<p>Astorino robot does not incorporate breaks on any joint. During power failure robot might collapse. User safety and vigilance is necessary.</p>
---	--





Always ensure the personal safety of users and others when operating the robot arm or starting the robot cell!

- In its basic version, the robot has no safety-related components for the robotic workstation. Such components may be required, depending on the target application. The basic version of the robot is provided with an emergency stop button.
- CE marking: The robot arm, when operating in factory applications, must undergo a risk assessment and comply with applicable safety regulations to ensure personal safety. Depending on the outcome of the assessment, further safety features should be integrated. These typically include safety relays and door switches. The person responsible here is the commissioning engineer. Educational applications do not require additional safety components.
- The robot controller includes a 24 V power supply that must be supplied with mains voltage (100/240 V). Please check the label on the power supply. Only qualified personnel can connect the power supply to the mains and put it into operation.
- Works carried out on the robot's electronic components should only be performed by qualified personnel. Check current guidelines for electrostatic discharges (ESD).
 - Always disconnect the robot from the power supply (100/240 V) when working on the robot base (controller) or any electronic components connected to the robot controller.
- Hot-plugging is forbidden! It could lead to a permanent damage to motor modules. Do not install or remove any modules or plug/disconnect connectors (e.g. emergency stop button, DIO modules, motor connectors) while the power is on.
- The robot arm must be placed on a stable surface and bolted or otherwise secured.
- Use and store the robot only in a dry and clean place.
- Use the system only in a room temperature (15° to 32°C) — recommended.

5.1.1. Signal words used

	<p style="text-align: center;">GENERAL WARNING SIGNS</p> <p>They are used to alert the product user to potential hazards. All safety statements that follow this symbol must be followed in order to prevent possible damage</p>
	<p style="text-align: center;">SAFETY INSTRUCTIONS</p> <p>This pictogram indicates safety-relevant behaviour of the operator</p>

5.1.2. Hazard warnings

	<p style="text-align: center;">WARNING OF PINCH INJURIES</p> <p>There is a risk of crushing due to driven moving parts (connecting plates). If grippers or other electrical or pneumatic components are used as actuators, the relevant regulations of the manufacturer must be observed.</p>
	<p style="text-align: center;">WARNING OF ENTANGLEMENT HAZARD</p> <p>There is danger of hair and/or clothing being drawn in. Do not wear open hair, loose clothing or jewellery. There is a risk of injury from getting entangled or pulled in! Do not put any part of body to the places marked by this sign</p>
	<p style="text-align: center;">WARNING OF HOT SURFACE</p> <p>There is danger of burn on when in contact with a skin</p>
	<p style="text-align: center;">WARNING OF DANGEROUS ELECTRICAL VOLTAGE</p> <p>The electrical drive should only be connected by qualified personnel. The applicable regulations must be observed and applied. The assembly device must be integrated in the local protective conductor system</p>

5.1.3. Guidelines, laws and standards

The machine has been designed according to the guidelines and standards given in the declaration of incorporation

Failure to observe the safety instructions increases the risk of accidents as well as the risk of damage to the machine.

5.1.4. Validity

Significant changes to the articulated arm with drive units can lead to this declaration of incorporation becoming invalid. User can change 3D printed parts without making modifications to the 3D models.

5.2. Safety instructions for personel



Staff must be trained and be familiar with hazardous situations that arm can perform.
Only trained persons must be employed on the machine!

5.3. Specific compoments

5.3.1. Safety devices

It is forbidden to remove or disable any safety device. If protective devices must be dismantled or disconnected for maintenance, repair or cleaning purposes, they must be re-installed and checked for efficacy after completion of the work.



The machine must not be operated in automatic mode if the protective equipment is not working or disassembled!
Robot cannot operate with more speed that 250mm/s therefore protective device other that Emergency stop button is not needed when working with safety clearance of at least 0.5m

5.3.2. Safety-relevant functions

The basic version of the robot control package does not include any safety-relevant functions. Depending on the application, they may possibly have to be added.

The robot arm as delivered is an incomplete machine in the sense of Machine Directive 2006/42/EC and does not yet fulfil all basic health and safety requirements. Before being used for the first time, the robot arm must be subjected to an EC conformity assessment procedure by the user, possibly together with other (incomplete) machines. For safe use, additional protective measures are necessary.

Note that the Machinery Directive has an exemption for 'machinery specially designed and constructed for research purposes for temporary use in laboratories'. However, a risk assessment should be conducted.

5.4. Electrical

Work on robot electronics should only be done by qualified personnel. Check the directives for electro- static discharge (ESD). The robot control system includes a 24V mains adapter that itself need a mains voltage (120/240V). Please check the label on the mains adapter. Only qualified personnel are permitted to connect the mains adapter to the mains and start it up. Always disconnect the robot from the mains (120/240V) on the electronics that are connected to the robot control system. NO hot plugging! This can permanently damage the motor modules. Do not install or remove any modules (e.g emergency OFF switch, 24V DIO modules or external relays, motor connections) while they are switched on.

5.5. Specific life cycles of the product

5.5.1. Transport

Transport of the machine should be done only in original box delivered with a robot. Transporting in any other way can damage the robot arm and will lead to invalidation of warranty.

5.5.2. Installation/Robot environment/Cleaning

Only trained and appropriately qualified personnel, who are familiar with the structure of this type of machine, must be assigned to install and commission the machine. The robot arm must be placed on a robust surface and screwed on.

- Use and store the robot arm only in a dry, clean environment.
- Use the system only at room temperature (5° to +50°C).
- Do not cover stepper motor drivers and stepper motor to ensure a sufficient flow of air to cool them down.



Cleaning work must only be carried out when the machine is at a standstill. Before starting the cleaning work, the machine must be switched off and isolated against accidental restart!

5.5.3. Dismantling

Decommissioning and disassembly of the machine must only be carried out by properly trained and qualified personnel.

6. Installation instructions



The robot must be installed on rigid surface. Only the existing mounting holes must be used. The articulated arm must be able to move freely in all directions for zeroing of all joints.

The machine used in other environment than laboratories is an INCOMPLETE MACHINE. In the delivered condition, it does not yet fulfil all safety requirements. It must only be operated after all the requirements of the Machinery Directive 2006/42/EC have been met.



Zero position of the Astorino robot arm.

6.1. Switch ON

<p>Connect and screw the power supply connector and ESTOP connector to the robot.</p>	
<p>Turn on the power supply and press the on/off switch. The green light diode (LED) should light up. On the side of the robot arm three leds should light UP. Yellow – 24V indicator Green – 5V indicator Red – error indicator</p> <p>If there is no error on the robot red diode should turn off after few seconds.</p>	

6.2. Connecting and moving the robot

	<p>Please refer to Operation manual of the astorino robot.</p>
---	--

7. Risk assessment

For each procedure of system setting, installation, teaching, operation, maintenance, disposal, etc., always make sure the instructions and specifications match the requirements of the purpose of robot use. Also, perform the adequate risk assessment without fail to reduce any avoidable risk.

7.1. SAFETY FEATURES

To safeguard the user, robot astorino is equipped with many safety features, including the following:

- All E-stops are hard-wired.
- All robot controllers are equipped with a redundant dual channel safety circuit. Both channels of the safety circuit must be closed to allow for robot operation in the teach and automatic playback modes.
- Velocities are limited to a maximum of 250 mm/s (10.0 in/s).
- JT1-JT3 are equipped with overtravel hardstops. Mechanical hardstops are capable of stopping the robot moving at full speed and with maximum payload.

7.2. RESIDUAL RISKS

7.2.1. Warning labels

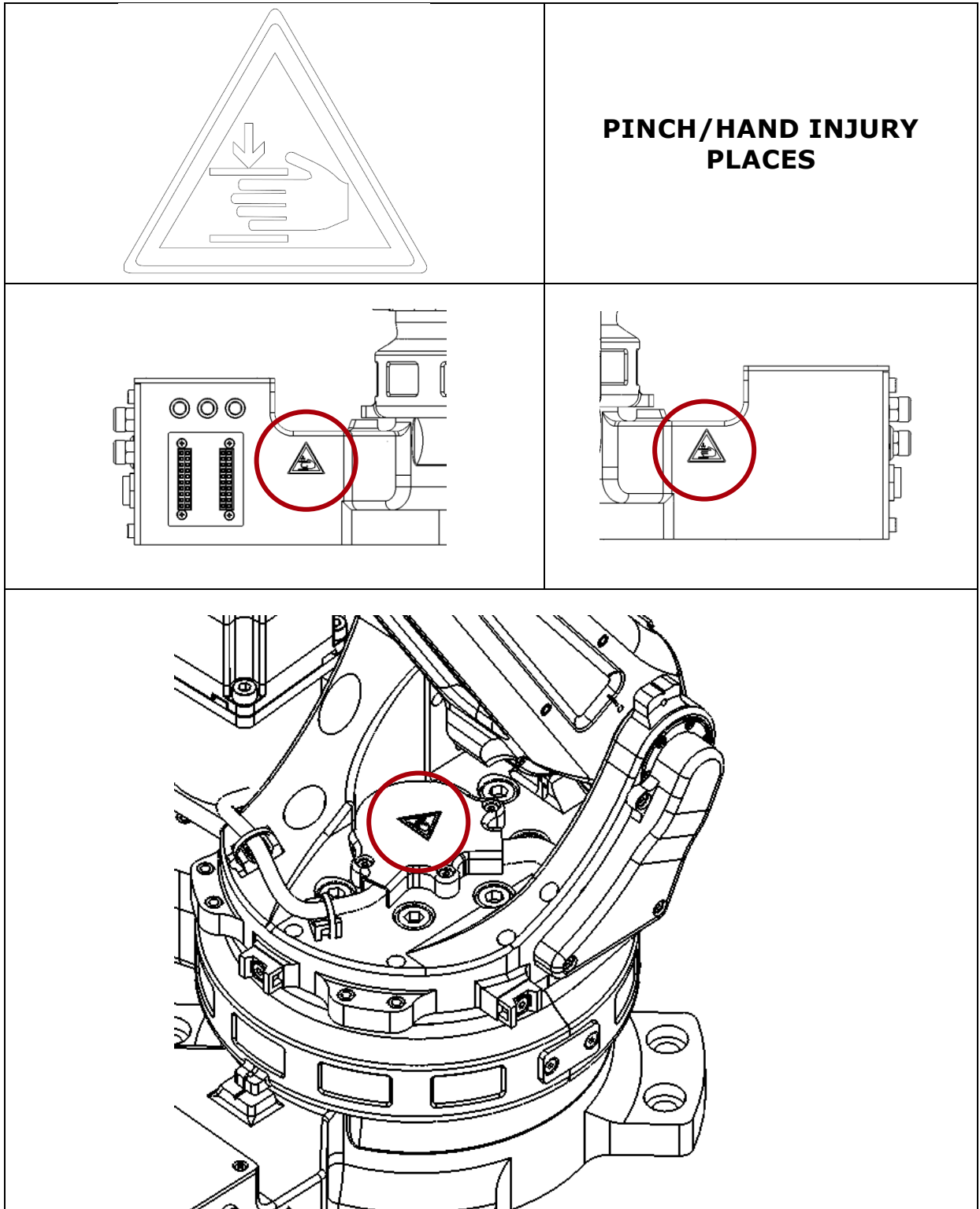

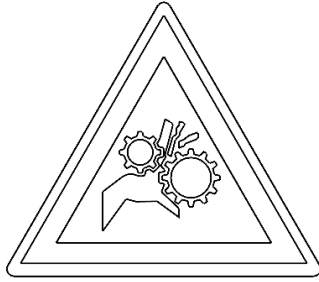

**MOVING PARTS WITH RISK
OF HAND INJURY**

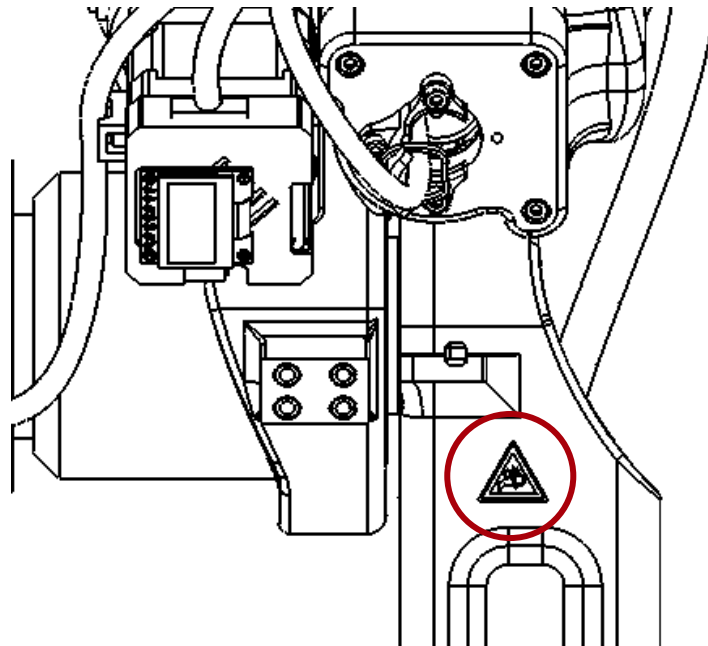
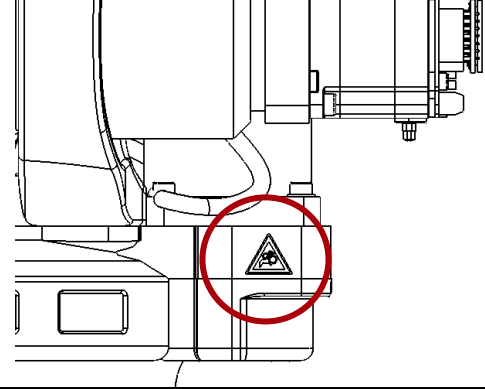
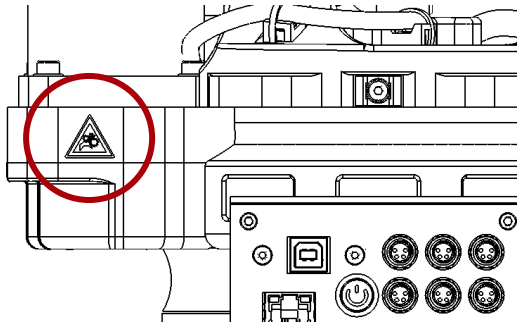



HOT SURFACE

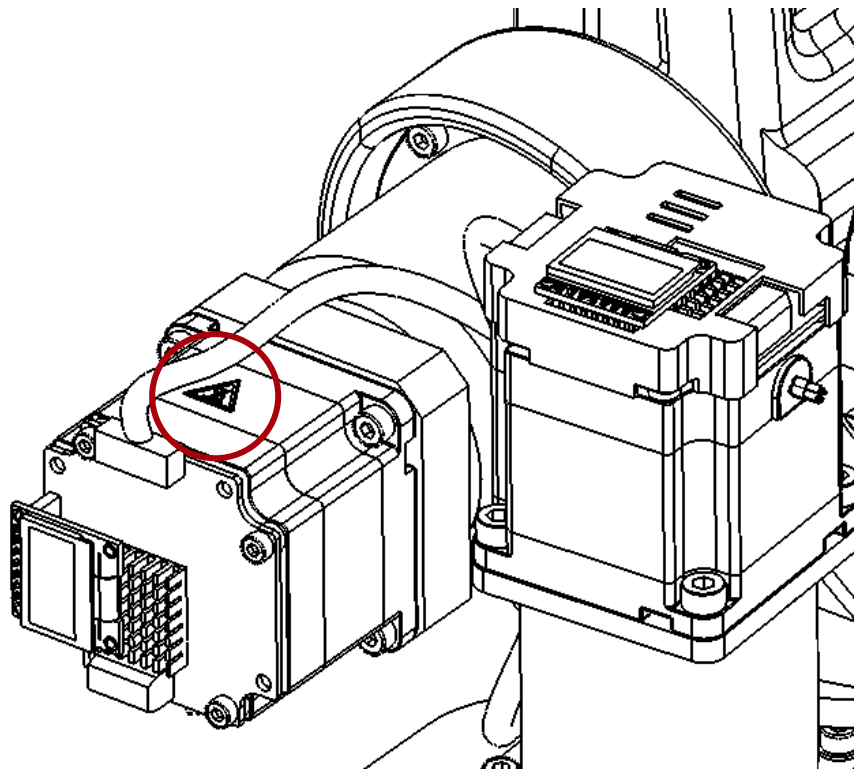

7.2.2. PINCH OR HAND INJURY PLACES

PINCH OR CRUSH INJURY – DO NOT PLACE ANY OBJECT ON THIS PLACE

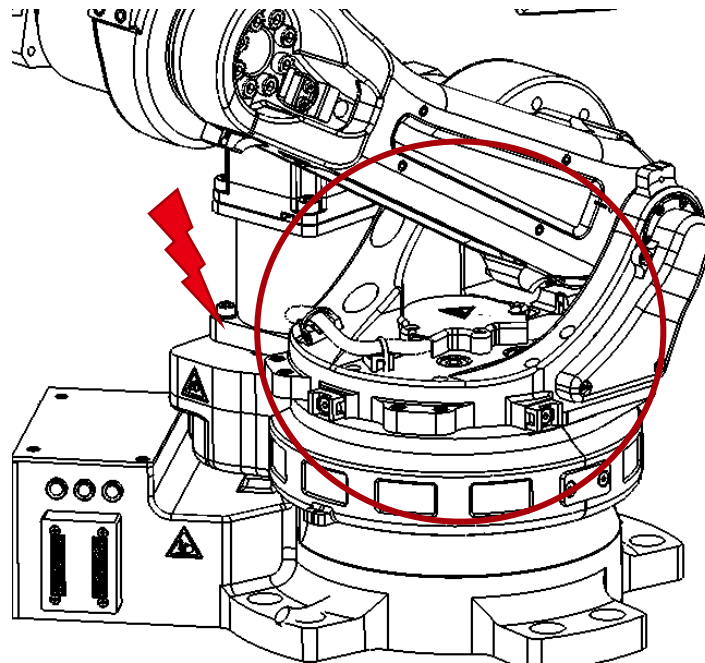
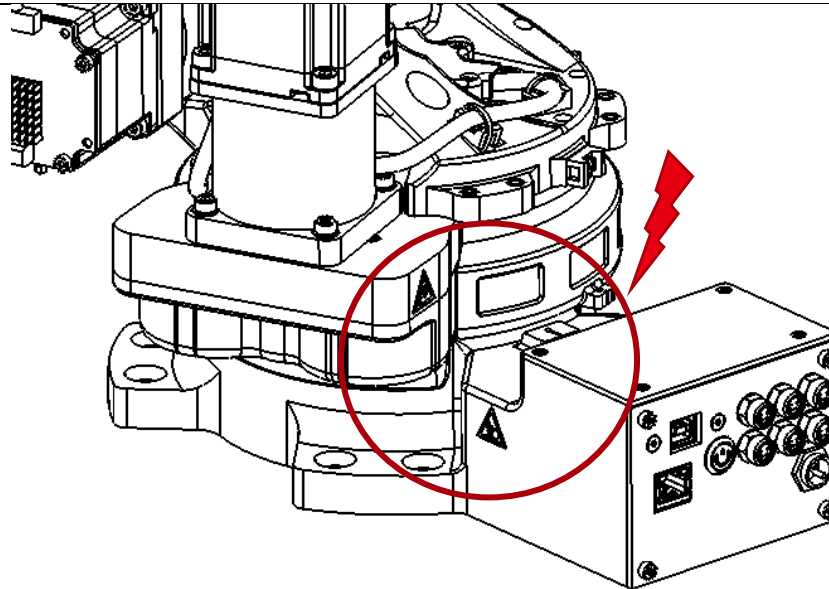

7.2.3. RESIDUAL RISKS IN CASE OF POWER LOSS



Astorino robot does not incorporate breaks on any joint. During power failure robot might collapse. User safety and vigilance is necessary.

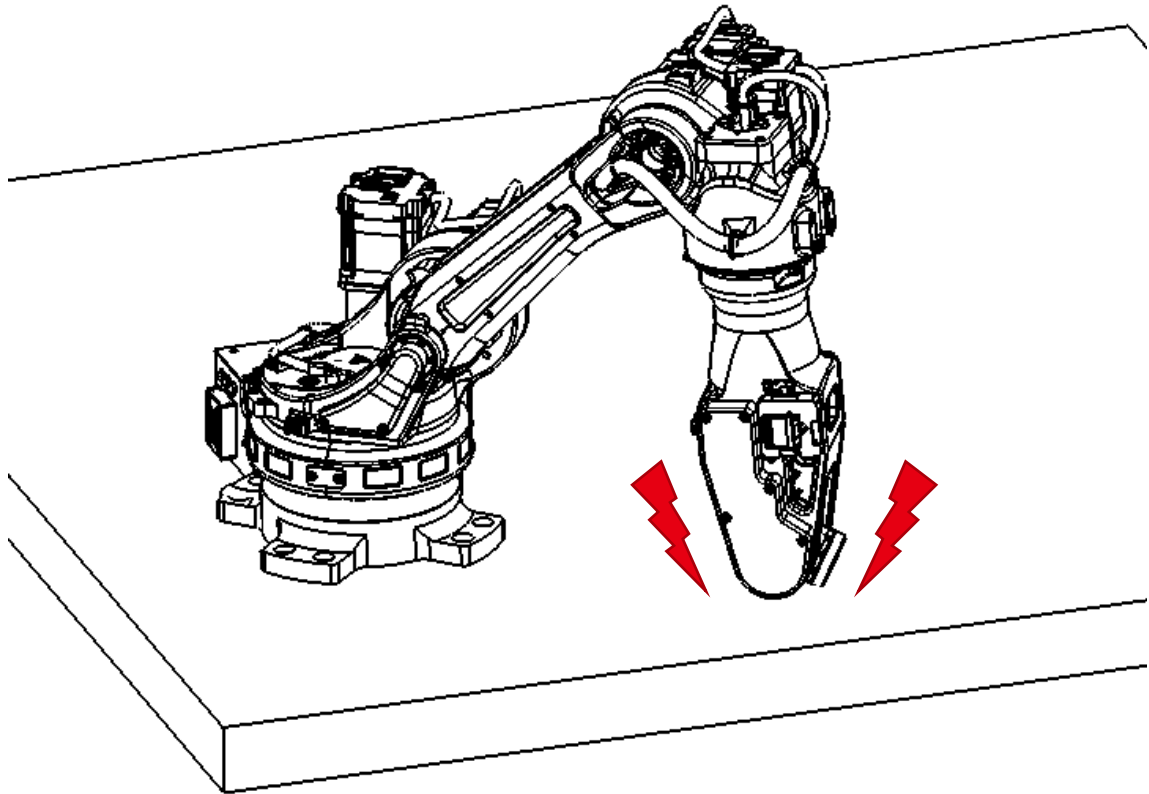

To decrease the risks of injury in power loss situations it is recommended to use emergency power supply (UPS) or to use astorino option – brakes on JT2/JT3

8. INSTALLATION

8.1. INSTALLATION ENVIRONMENT

- The installation site of the robot must fulfill all the following environmental conditions:
- When robot arm is installed on the floor, the levelness must be within $\pm 5^\circ$.
- Be sure that the floor/stand has sufficient rigidity.
- Secure a flat place to prevent the base section from receiving undue force.
- Keep the ambient temperature during operation within the range of 0°C to 45°C
- Keep the relative humidity during operation within the range of 35% to 85%RH without dew condensation.
- The altitude of the installation place should be within the range of 0 m to 1000 m above mean sea level.
- The robot installing place should be free from dust, dirt, smoke, water, and other foreign matters.
- The robot installing place should be free from flammable or corrosive liquid or gas.
- The robot installing place should be free from excessively strong vibration. (0.5 G or less)
- The robot installing place should be free from electric noise interference.
- Place where power satisfying the specification is supplied.
- The robot installing place should be sufficiently larger than the motion range of robot arm.

Safety fence must enclose area larger than the maximum motion range of fully equipped robot arm (with tools) so it does not interfere with the surrounding objects.

8.2. SAFETY MEASURES CONCERNING ROBOT INSTALLATION

When astorino robot arm is not being installed in the laboratory then place the robot arm within the safeguarding devices (guard, fence, equipment, etc. provided for preventing hazards) so that the robot arm is put off limits. Also, install an emergency stop device in an easily accessible area within reach of the operator.

Safety guarding zone (area surrounded by the safety fence) should be built so as to prevent the robot arm from jumping over or extending beyond the fence in the event of breakdown and/or error.

Minimize the number of doors on the safeguarding devices (preferably only one). The door should be equipped with a safety plug which must be removed manually in order to open/close the door. Then, set motor power to be turned OFF if plug is removed during automatic operation. Confirm that safety devices such as EMERGENCY STOP switch and safety plug function normally before entering the safeguarding devices.

Display the robot state clearly, such as: automatic mode, teaching, and emergency stop, etc. on the safeguarding devices so the current condition of the robot can be seen by everybody.

Limit the robot operating personnel to only those who have taken and completed the training course(s) authorized by Astor/Kawasaki.



ASTOR Sp. z o.o.

ul. Smoleńsk 29, 31-112 Kraków, Poland.

tel.: +48 (12) 428 63 06

e-mail: astorino@astor.com.pl

NIP: PL6760105127

